

AMS سری

پمپ سانترفیوژ استیل

پمپ های استیل سری AMS با بدنه و پروانه استیل ۳۰۴ در رنج وسیعی از مصارف ساختمانی، صنعتی و کشاورزی کاربرد دارند.



کاربردها

- تأمین آب مجتمع های مسکونی، اداری، بیمارستانها و ...
- سیستم های تهویه مطبوع، حرارت مرکزی و غیره
- آبیاری باغات و گلخانه و مصارف کشاورزی و پرورش ماهی و طیور
- مصارف صنعتی و معدنی

مشخصات مدل های AMS 70~120

Hydraulic Performance Curves

منحنی های هیدرولیکی

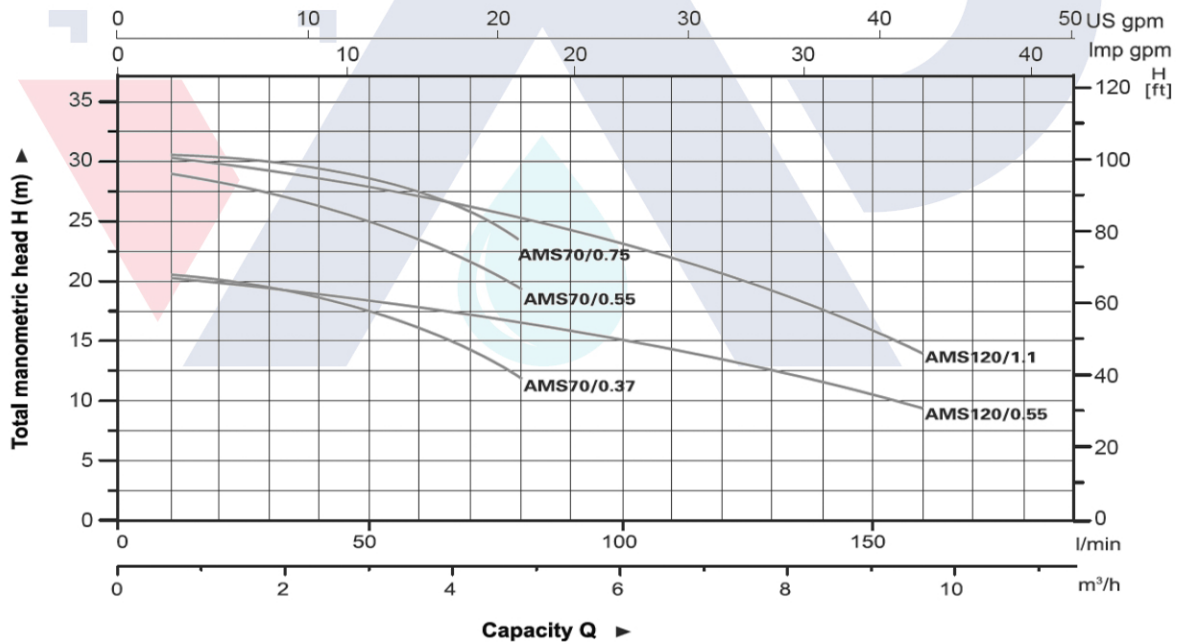

Technical Data

جدول مشخصات فنی

| MODEL | | POWER | | Capacity Q | | | | | | | | | | | | |
|--------------|-------------|-------|------|------------|------|------|------|------|------|------|------|------|------|-----|------|---|
| Single Phase | Three Phase | kW | HP | l/min | | 0 | 30 | 40 | 60 | 80 | 100 | 120 | 140 | 160 | 180 | |
| | | | | m³/h | | 0 | 1.8 | 2.4 | 3.6 | 4.8 | 6 | 7.2 | 8.4 | 9.6 | 10.8 | |
| AMS70/0.37 | AMS70/0.37 | 0.37 | 0.5 | H (m) | 20.9 | 19.0 | 18.1 | 15.7 | 12.1 | - | - | - | - | - | - | |
| AMS70/0.55 | AMS70/0.55 | 0.55 | 0.75 | | 29.5 | 27.3 | 26.3 | 23.4 | 19.1 | - | - | - | - | - | - | - |
| AMS70/0.75 | AMS70/0.75 | 0.75 | 1.0 | | 30.4 | 28.5 | 27.8 | 26.0 | 23.0 | - | - | - | - | - | - | - |
| AMS120/0.55 | AMS120/0.55 | 0.55 | 0.75 | | 20.2 | - | - | 17.9 | 16.6 | 15.1 | 13.3 | 11.2 | 8.7 | - | - | - |
| AMS120/1.1 | AMS120/1.1 | 1.1 | 1.5 | | 30.2 | - | - | 26.7 | 25.1 | 23.3 | 21.2 | 19.0 | 16.4 | - | - | - |

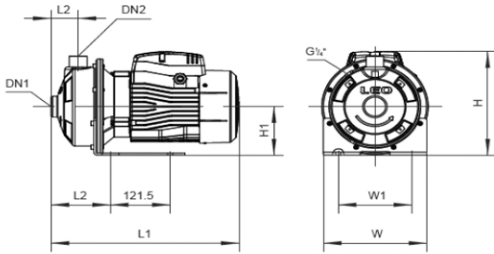

Dimension

مشخصات ابعادی

| Model | Ports | | L (mm) | W (mm) | H (mm) | L ₁ (mm) | L ₂ (mm) | W ₁ (mm) | H ₁ (mm) |
|-------------|--------|-----|--------|--------|--------|---------------------|---------------------|---------------------|---------------------|
| | DN1 | DN2 | | | | | | | |
| AMS70/0.37 | 1 1/4" | 1" | 332 | 210 | 224 | 119 | 55 | 149 | 110 |
| AMS70/0.55 | 1 1/4" | 1" | 332 | 210 | 224 | 119 | 55 | 149 | 110 |
| AMS70/0.75 | 1 1/4" | 1" | 381 | 210 | 234 | 119 | 55 | 149 | 110 |
| AMS120/0.55 | 1 1/4" | 1" | 332 | 210 | 224 | 119 | 55 | 149 | 110 |
| AMS120/1.1 | 1 1/4" | 1" | 381 | 210 | 234 | 119 | 55 | 149 | 110 |

Materials Table

| No. | Part | Material |
|-----|-----------------|----------------|
| 1 | Bottom support | Steel |
| 2 | Pump body | AISI 304 |
| 3 | Diffuser | AISI 304 |
| 4 | Impeller | AISI 304 |
| 5 | O-ring | NBR |
| 6 | Airproof plate | AISI 304 |
| 7 | Support | ZL102 |
| 8 | Mechanical seal | Silicon/carbon |
| 9 | Ball bearing | |
| 10 | Rotor | |
| 11 | Stator | |
| 12 | Fan | PP |
| 13 | Rear housing | ZL102 |
| 14 | Fan cover | PP |
| 15 | Terminal box | ABS |

اجزای پمپ

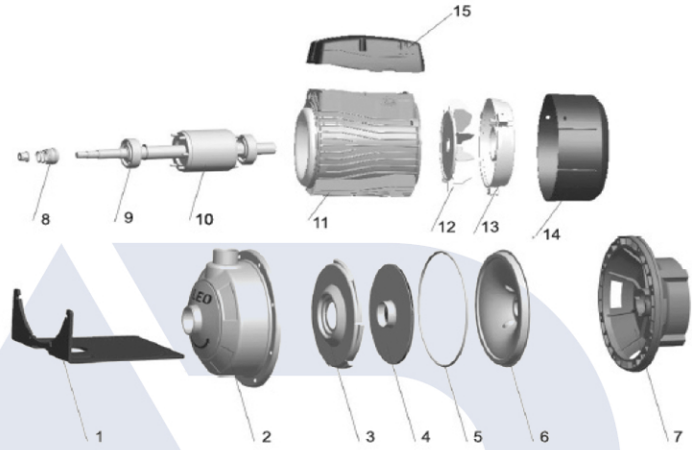

مشخصات مدل های AMS 210~370

Hydraulic Performance Curves

منحنی های هیدرولیکی

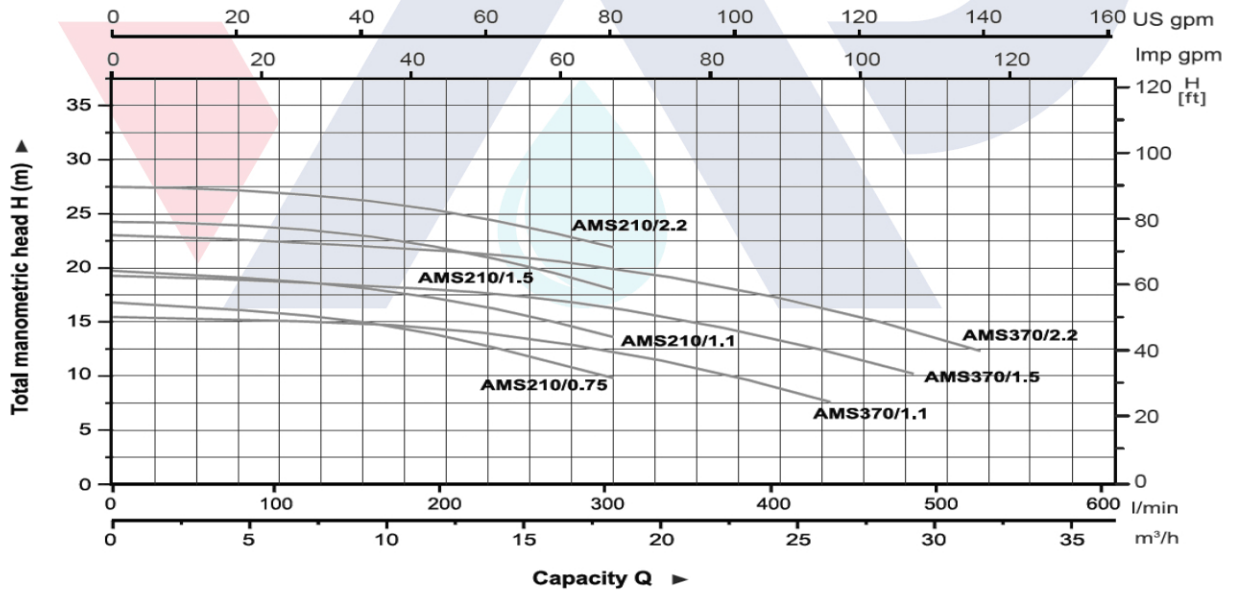

Technical Data

جدول مشخصات فنی

| MODEL | | POWER | | Capacity Q | | | | | | | | | | | | | | | | |
|--------------|-------------|-------|-----|-------------------|------|-----|-----|------|------|------|------|------|------|------|------|------|------|------|------|-----|
| Single Phase | Three Phase | kW | HP | l/min | 0 | 30 | 60 | 100 | 120 | 140 | 160 | 180 | 200 | 250 | 300 | 350 | 400 | 430 | 480 | 520 |
| | | | | m ³ /h | 0 | 1.8 | 3.6 | 6 | 7.2 | 8.4 | 9.6 | 10.8 | 12 | 15 | 18 | 21 | 24 | 26 | 29 | 31 |
| AMSm210/0.75 | AMS210/0.75 | 0.75 | 1.0 | H (m) | 16.8 | - | - | - | 15.6 | 15.2 | 14.8 | 14.2 | 13.6 | 11.9 | 9.8 | - | - | - | - | - |
| AMSm210/1.1 | AMS210/1.1 | 1.1 | 1.5 | 19.7 | - | - | - | 18.7 | 18.3 | 18.0 | 17.5 | 17.1 | 15.6 | 13.6 | - | - | - | - | - | |
| AMSm210/1.5 | AMS210/1.5 | 1.5 | 2.0 | 24.2 | - | - | - | 23.5 | 23.2 | 22.8 | 22.4 | 21.8 | 20.2 | 18.0 | - | - | - | - | - | |
| AMSm210/2.2 | AMS210/2.2 | 2.2 | 3.0 | 27.5 | - | - | - | 26.7 | 26.5 | 26.1 | 25.7 | 25.2 | 23.8 | 21.9 | - | - | - | - | - | |
| AMSm370/1.1 | AMS370/1.1 | 1.1 | 1.5 | 15.4 | - | - | - | - | - | - | 14.7 | 14.4 | 13.5 | 12.3 | 10.8 | 8.9 | 7.6 | - | - | |
| AMSm370/1.5 | AMS370/1.5 | 1.5 | 2.0 | 19.3 | - | - | - | - | - | - | - | 18.1 | 17.3 | 16.3 | 15.0 | 13.3 | 12.3 | 10.2 | - | |
| AMSm370/2.2 | AMS370/2.2 | 2.2 | 3.0 | 23.1 | - | - | - | - | - | - | - | 21.7 | 20.9 | 20.0 | 18.8 | 17.2 | 16.2 | 14.2 | 12.3 | |

مشخصات ابعادی

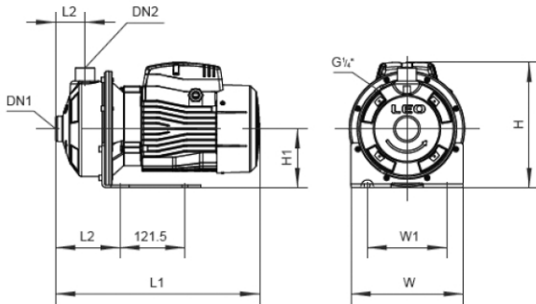

Dimension

| Model | Ports | | L (mm) | W (mm) | H (mm) | L ₁ (mm) | L ₂ (mm) | W ₁ (mm) | H ₁ (mm) |
|-------------|--------|--------|--------|--------|--------|---------------------|---------------------|---------------------|---------------------|
| | DN1 | DN2 | | | | | | | |
| AMS210/0.75 | 1 1/2" | 1 1/4" | 392 | 210 | 234 | 129 | 55 | 149 | 110 |
| AMS210/1,1 | 1 1/2" | 1 1/4" | 392 | 210 | 234 | 129 | 55 | 149 | 110 |
| AMS210/1.5 | 1 1/2" | 1 1/4" | 440 | 210 | 250 | 129 | 55 | 149 | 110 |
| AMS210/2.2 | 1 1/2" | 1 1/4" | 440 | 210 | 250 | 129 | 55 | 149 | 110 |
| AMS370/1,1 | 2" | 1 1/4" | 392 | 210 | 234 | 129 | 55 | 149 | 110 |
| AMS370/1,5 | 2" | 1 1/4" | 440 | 210 | 250 | 129 | 55 | 149 | 110 |
| AMS370/2.2 | 2" | 1 1/4" | 440 | 210 | 250 | 129 | 55 | 149 | 110 |

اجزای پمپ

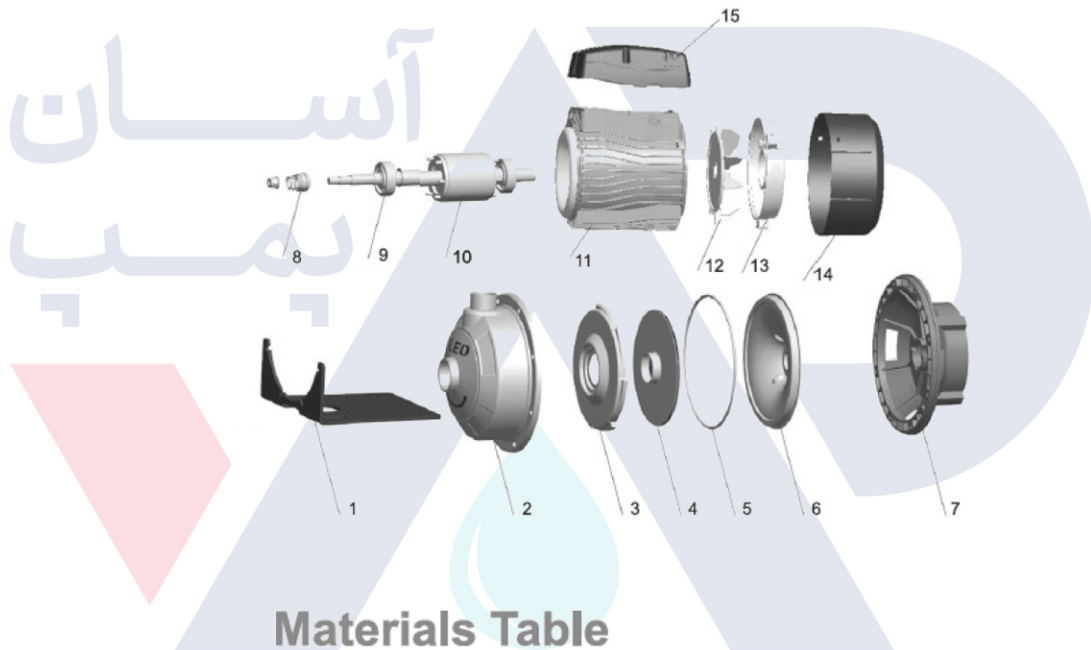

Materials Table

| No. | Part | Material |
|-----|-----------------|----------------|
| 1 | Bottom support | Steel |
| 2 | Pump body | AISI 304 |
| 3 | Diffuser | AISI 304 |
| 4 | Impeller | AISI 304 |
| 5 | O-ring | NBR |
| 6 | Airproof plate | AISI 304 |
| 7 | Support | ZL102 |
| 8 | Mechanical seal | Silicon/carbon |
| 9 | Ball bearing | |
| 10 | Rotor | |
| 11 | Stator | |
| 12 | Fan | PP |
| 13 | Rear housing | ZL102 |
| 14 | Fan cover | PP |
| 15 | Terminal box | ABS |