

## سری XSP

### پمپ لجن کش چدنی تک فاز

پمپ های سری XSP با بدنه چدنی مقاوم در مقابل خوردگی برای نصب مستغرق در مایع طراحی و ساخته شده است. این پمپ ها برای پمپاژ پساب و فاضلاب در مصارف خانگی، شهری و صنعتی مناسب می باشند.



### کاربردها

- تخلیه فاضلاب کارخانه ها، سایت های ساخت و ساز و واحدهای تجاری و پروژه های شهری
- سیستم تخلیه در واحدهای تصفیه فاضلاب شهری و محله های مسکونی
- مورد استفاده در استخرها و آبیاری مزارع در حومه شهر

### مشخصات فنی

#### مشخصات هیدرولیکی

دبی: از 5 تا 1300 متر مکعب بر ساعت

هد: حداکثر ارتفاع 22 متر

دهانه خروجی: 1 ¼ - 2 ½ اینچ

حداکثر عمق غوطه وری: 5 متر

درجه PH مایع: 4 - 10

محدوده دمای سیال: حداکثر تا 40 درجه سانتیگراد

محدوده ویسکوزیته سینماتیکی سیال: ~ 23 \* 7\*

حداکثر دانسیته (چگالی) سیال: 1.2 \* /Kg

کیفیت مورد نیاز سیال: انتقال آب یا سیالات ویسکوز همراه با مواد جامد ریز با مشخصه گرانروی سینماتیکی تا 23\*

#### مشخصات الکتروموتور

توان: 0.18 تا 2.2 کیلو وات

کلاس حفاظت موتور: IP 68

کلاس عایق: B

برق ورودی استاندارد:

تکفاز 1 50 Hz - 220 V 3X

#### ویژگی های خاص

دارای فلوتر برای عملکرد اتوماتیک پمپ

سیم پیچ الکتروموتورها از جنس مس

محافظ حرارتی داخلی

#### متریال

بدنه پمپ: چدن

پروانه: چدن

شفت: استیل

سیل مکانیکی: کربن / سرامیک

کد شناسایی مدل پمپ

## XSP 8 – 7 / 0.18 I

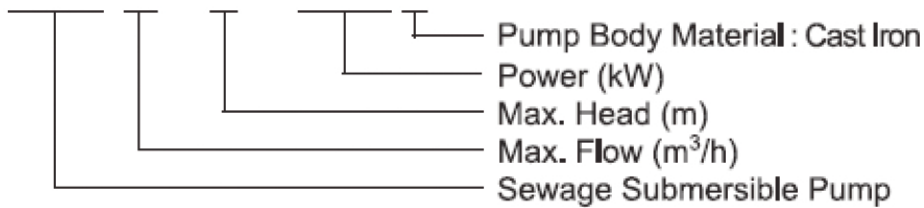

مشخصات پمپ های سری XSP (0.18 – 0.25 kw)

منحنی های هیدرولیکی

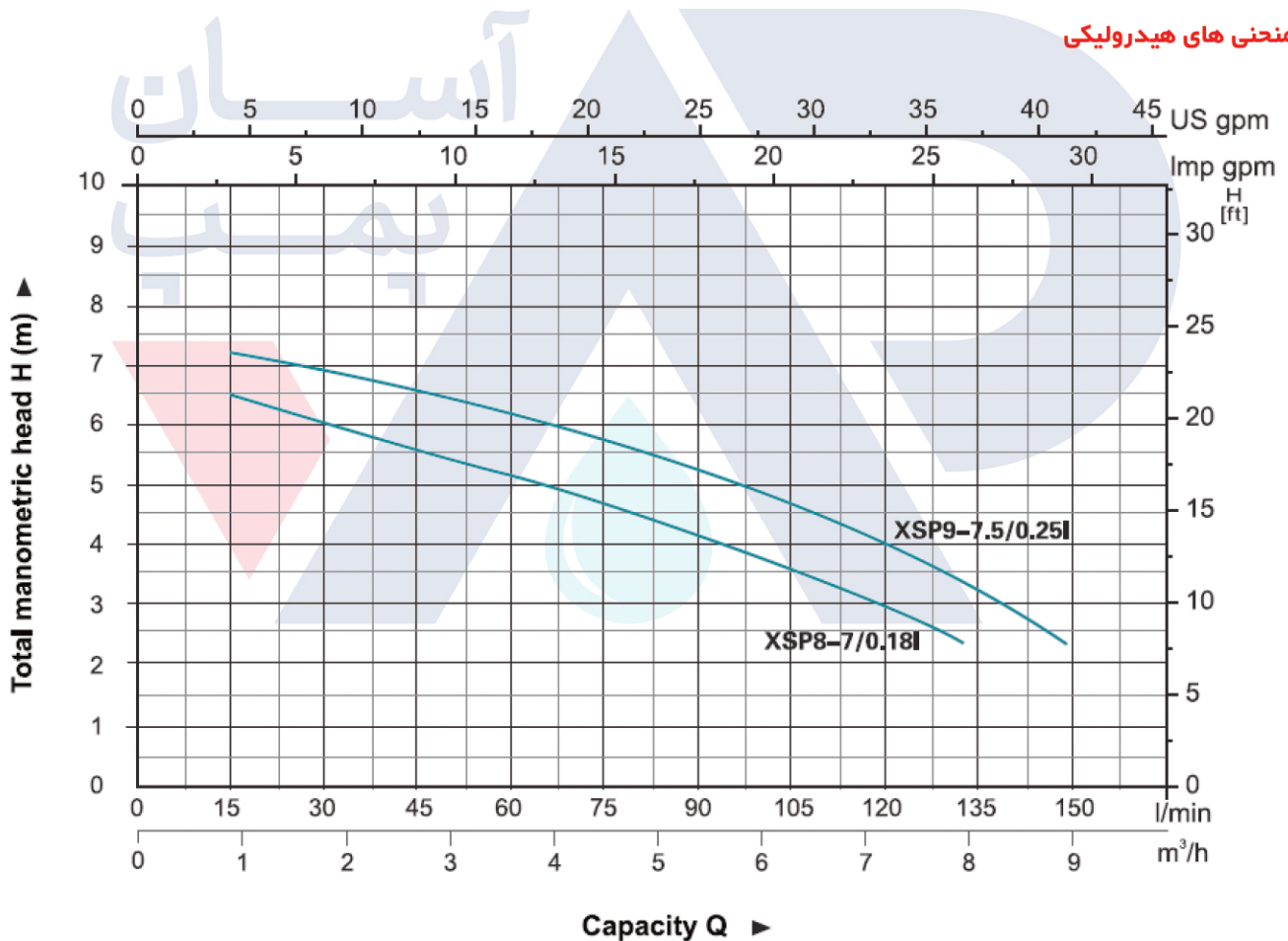

جدول مشخصات فنی

Model	Power		Outlet diameter (mm)	Voltage (V/Hz)	Max.flow (l/min)	Max.head (m)	Max.dia. of particle (mm)	GW (kgs)	Packing size (mm)	Quantity (PCS/20 TEU)
	(kW)	HP								
XSP8-7/0.18I	0,18	0,25	40,32,25	220/50	133	7	15	9	185x180x360	2322
XSP9-7.5/0.25I	0.25	0.33	40,32,25	220/50	150	7.5	15	10	185x180x380	2174

مشخصات ابعادی

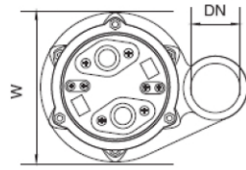
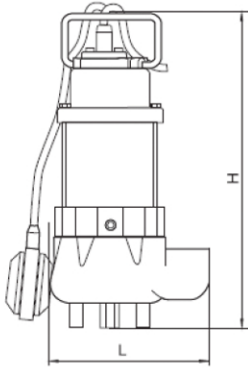

Dimension

Model	DN	L (mm)	W (mm)	H (mm)
XSP8-7/0.18l	1 1/4"	166	121	335
XSP9-7.5/0.25l		166	121	355

اجزای پمپ

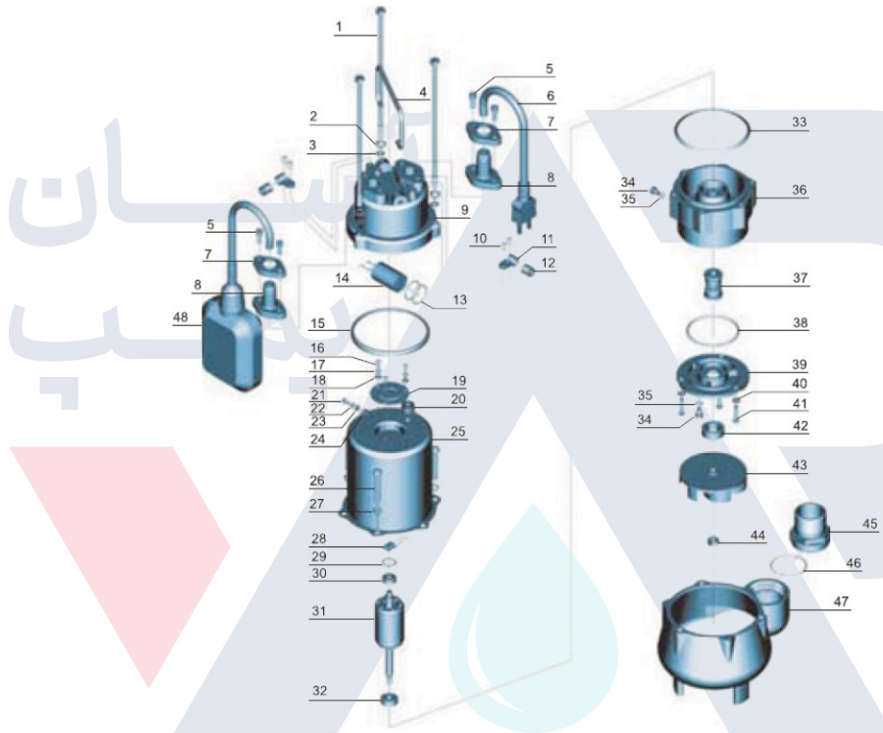

No.	Part	Material	No.	Part	Material
1	Bolt	Stainless steel	25	Stator	
2	Stretching washer	Stainless steel	26	Screw	Stainless steel
3	Washer	Stainless steel	27	Stretching washer	Stainless steel
4	Handle	Stainless steel	28	Thermal protector	
5	Screw	Stainless steel	29	Wave washer	65Mn
6	Cable		30	Ball bearing	
7	Flange	Stainless steel	31	Rotor	
8	Cable protector	CR	32	Ball bearing	
9	Capacitor cover	HT200	33	Rubber washer	NBR
10	Screw	Stainless steel	34	Screw	Stainless steel
11	Cable presser	Stainless steel	35	O-ring	NBR
12	Protector	NR	36	Connection part	HT200
13	O-ring	NBR	37	Mechanical seal	Carbon/Ceramic
14	Capacitor		38	O-ring	NBR
15	Rubber washer	NBR	39	Oil chamber cover	HT200
16	Screw	Steel	40	Washer	Stainless steel
17	Stretching washer	65Mn	41	Screw	Stainless steel
18	Washer	Steel	42	Oil seal	
19	Press plate	Steel	43	Impeller	PA66
20	Cable holder	NBR	44	Nut	Stainless steel
21	Screw	CuZn40	45	Connector	ABS
22	Stretching washer	65Mn	46	O-ring	NBR
23	Washer	CuZn40	47	Pump body	HT200
24	Nut	Stainless steel	48	Float switch	

### مشخصات پمپ های سری XSP (0.45 – 0.75) kw

#### منحنی های هیدرولیکی

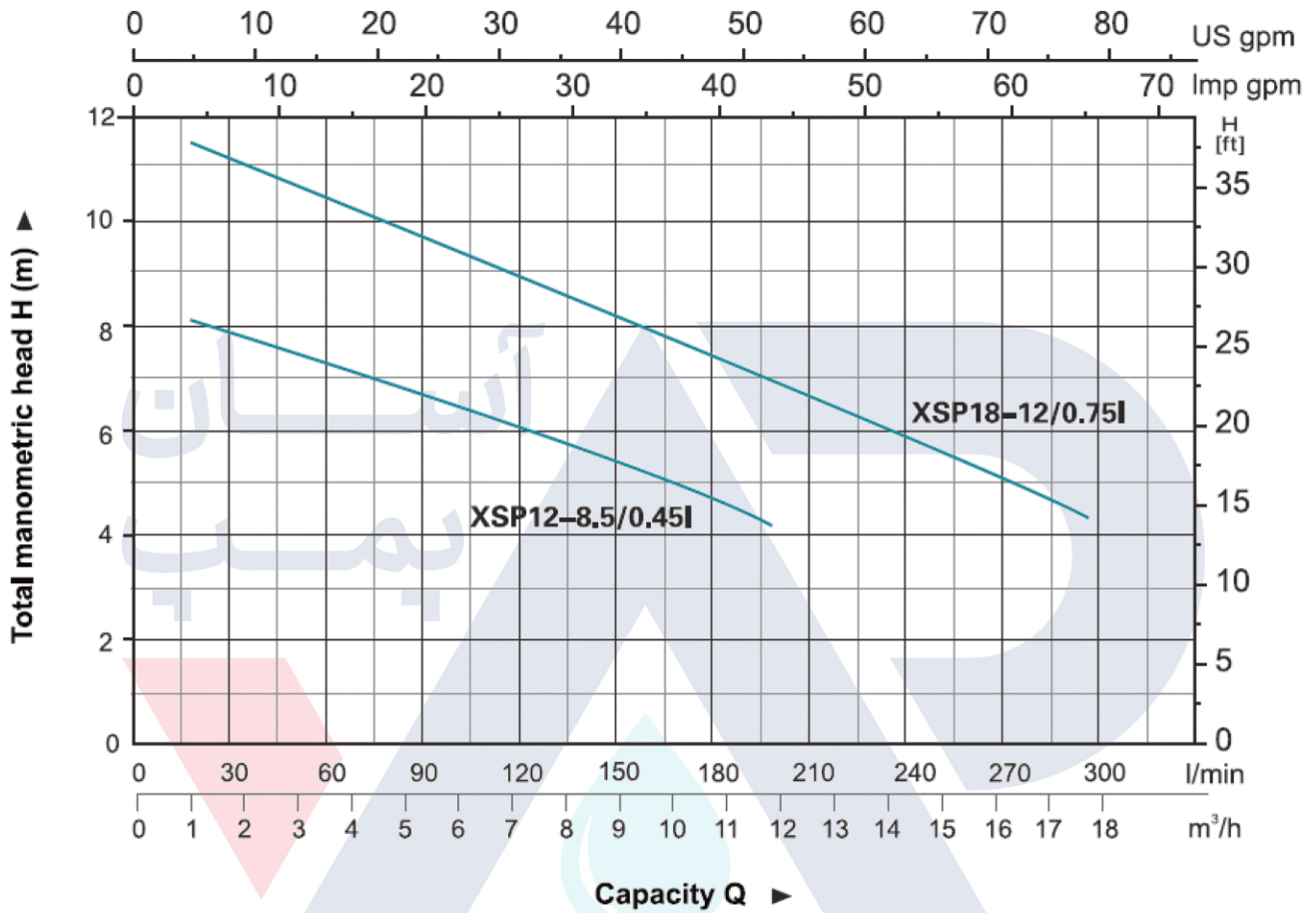

#### جدول مشخصات فنی

Model	Power		Outlet diameter (mm)	Voltage (V/Hz)	Max.flow (l/min)	Max.head (m)	Max.dia. of particle (mm)	GW (kgs)	Packing size (mm)	Quantity (PCS/20' TEU)
	(kW)	HP								
XSP12-8.5/0.45l	0.45	0.6	50	220/50	200	8.5	25	18.2	495x263x222	1010
XSP18-12/0.75l	0.75	1.0	50	220/50	300	12	25	20.2	540x265x195	1056

مشخصات ابعادی

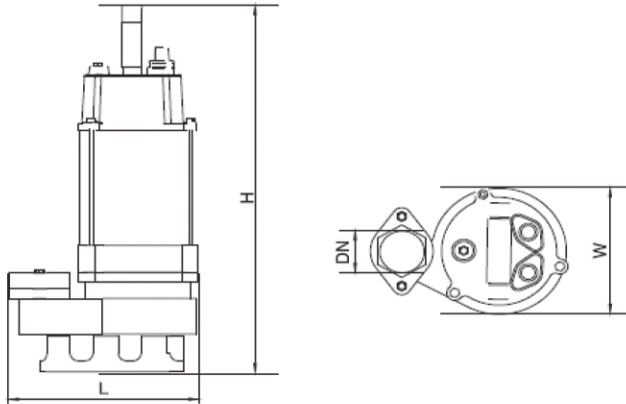

Model	DN	L (mm)	W (mm)	H (mm)
XSP12-8.5/0.45I	2"	225	150	450
XSP18-12/0.75I		226	159	500

اجزای پمپ

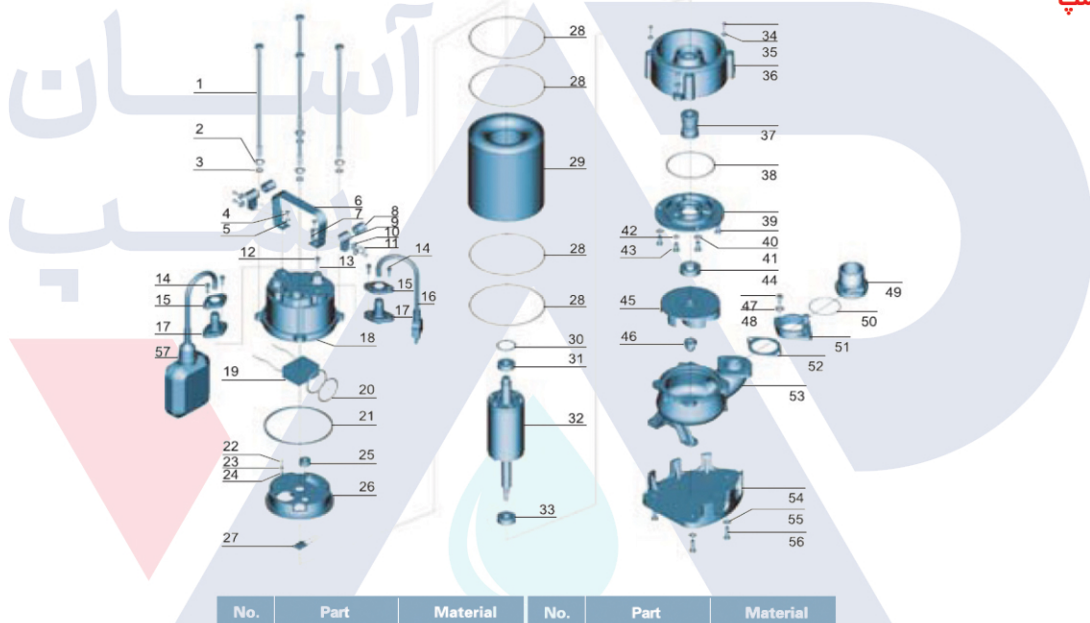

No.	Part	Material	No.	Part	Material
1	Bolt	Stainless steel	30	Wave washer	65Mn
2	Stretching washer	Stainless steel	31	Ball bearing	
3	Washer	Stainless steel	32	Rotor	
4	Bolt	Stainless steel	33	Ball bearing	
5	Washer	Stainless steel	34	Screw	Stainless steel
6	Handle	Stainless steel	35	Washer	Stainless steel
7	Nut	Stainless steel	36	Connection part	HT200
8	Protector	NR	37	Mechanical seal	Carbon/Ceramic
9	Cable presser	Stainless steel	38	O-ring	NBR
10	Washer	Stainless steel	39	Oil chamber cover	HT200
11	Screw	Stainless steel	40	Screw	Stainless steel
12	Bolt	Stainless steel	41	Washer	Stainless steel
13	O-ring	NBR	42	O-ring	NBR
14	Screw	Stainless steel	43	Screw	Stainless steel
15	Flange	Stainless steel	44	Oil seal	
16	Cable		45	Impeller	HT200
17	Cable protector	CR	46	Nut	Stainless steel
18	Capacitor cover	HT200	47	Bolt	Stainless steel
19	Capacitor		48	Washer	Stainless steel
20	O-ring	NBR	49	Connector	ABS
21	Rubber washer	NBR	50	O-ring	NBR
22	Screw	CuZn40	51	Connector nut	HT200
23	Stretching washer	65Mn	52	Rubber washer	NBR
24	Washer	CuZn40	53	Pump body	HT200
25	Cable holder	NBR	54	Base plate	HT200
26	Motor cover	HT200	55	Washer	Stainless steel
27	Thermal protector		56	Screw	Stainless steel
28	O-ring	NBR	57	Float switch	
29	Stator				

## مشخصات پمپ های سری (XSP 1.1 kw)

منحنی های هیدرولیکی

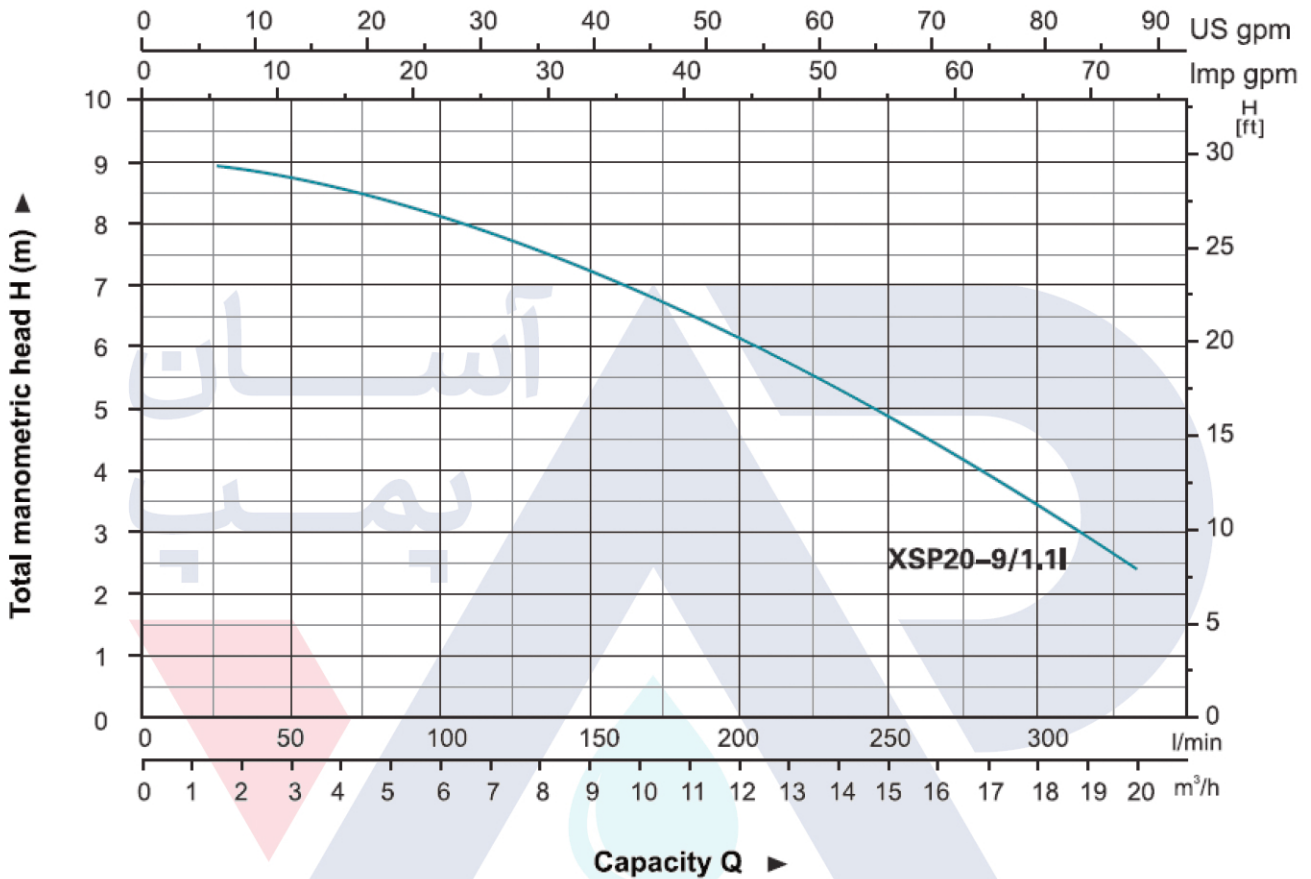

## جدول مشخصات فنی

Model	Power		Outlet diameter (mm)	Voltage (V/Hz)	Max.flow (l/min)	Max.head (m)	Max.dia. of particle (mm)	GW (kgs)	Packing size (mm)	Quantity (PCS/20' TEU)
	(kW)	HP								
XSP20-9/1.1I	1.1	1.5	50	220/50	333	9	35	20.9	580x320x250	681

### مشخصات ابعادی

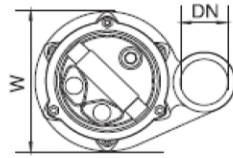
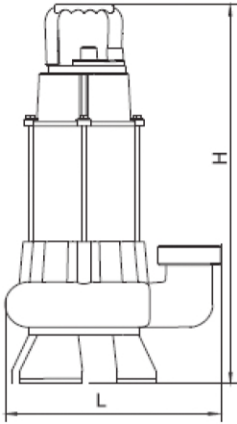

Model	DN	L (mm)	W (mm)	H (mm)
XSP20-9/1.1I	2"	280	200	530

### اجزای پمپ

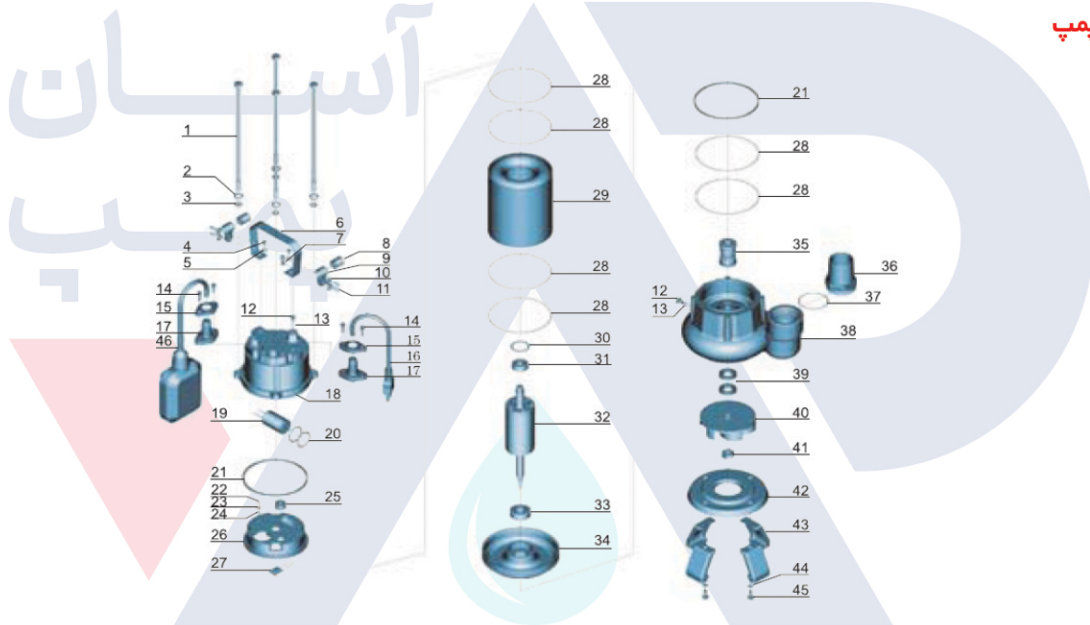

No.	Part	Material	No.	Part	Material
1	Bolt	Stainless steel	24	Washer	CuZn40
2	Stretching washer	Stainless steel	25	Cable holder	NBR
3	Washer	Stainless steel	26	Upper cover	HT200
4	Bolt	Stainless steel	27	Thermal protector	
5	Washer	Stainless steel	28	O-ring	NBR
6	Handle	Stainless steel	29	Stator	
7	Nut	Stainless steel	30	Wave washer	65Mn
8	Protector	NR	31	Ball bearing	
9	Cable presser	Stainless steel	32	Rotor	
10	Washer	Stainless steel	33	Ball bearing	
11	Screw	Stainless steel	34	Lower cover	HT200
12	Bolt	Stainless steel	35	Mechanical seal	Carbon/Ceramic
13	O-ring	NBR	36	Connector	ABS
14	Screw	Stainless steel	37	O-ring	NBR
15	Flange	Stainless steel	38	Pump body	HT200
16	Cable		39	Oil seal	
17	Cable protector	CR	40	Impeller	HT200
18	Capacitor cover	HT200	41	Nut	Stainless steel
19	Capacitor		42	Pump cover	Stainless steel
20	O-ring	NBR	43	Base plate	Stainless steel
21	Rubber washer	NBR	44	Washer	Stainless steel
22	Screw	CuZn40	45	Bolt	Stainless steel
23	Stretching washer	65Mn	46	Float switch	

## مشخصات پمپ های سری XSP (1.5 – 2.2 kw)

### منحنی های هیدرولیکی

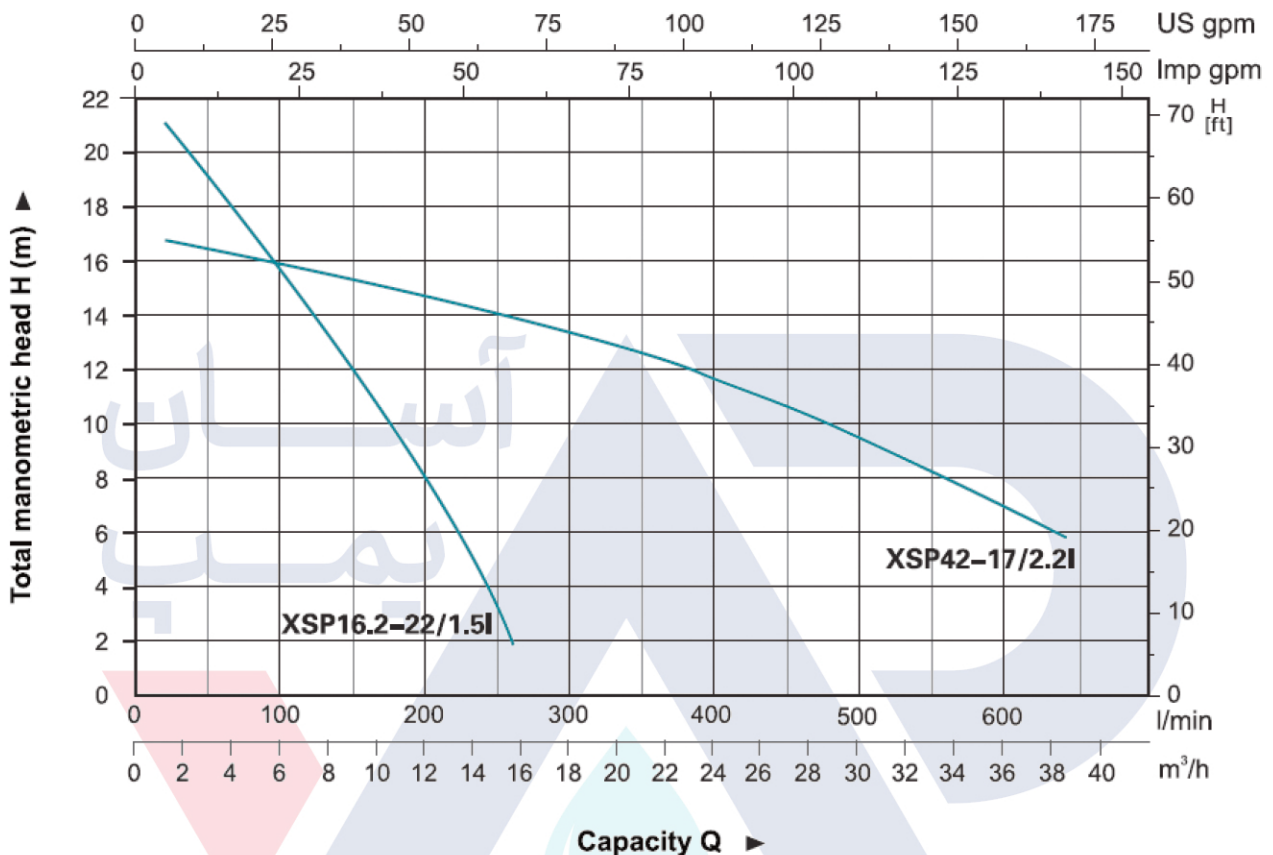

### جدول مشخصات فنی

Model	Power		Outlet diameter (mm)	Voltage (V/Hz)	Max.flow (l/min)	Max.head (m)	Max.dia. of particle (mm)	GW (kgs)	Packing size (mm)	Quantity (PCS/20 TEU)
	(kW)	HP								
XSP16,2-22/1,5l	1,5	2,0	40	220/50	270	22	10	27,6	585x350x245	540
XSP42-17/2,2l	2,2	3,0	75	220/50	700	17	20	29,7	585x350x245	540

مشخصات ابعادی

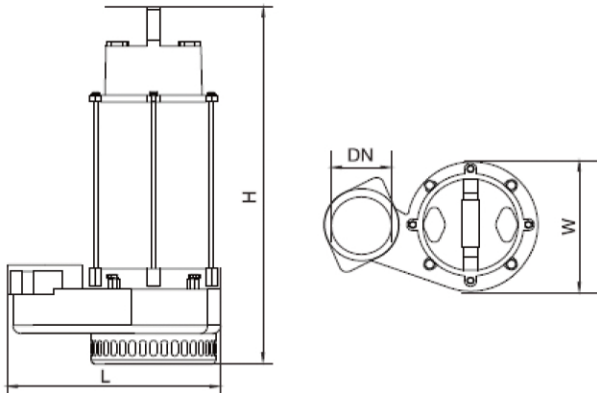

Model	DN	L (mm)	W (mm)	H (mm)
XSP16,2-22/1,5	2"	308	198	530
XSP42-17/2,2	2 1/2"	302	190	535

اجزای پمپ

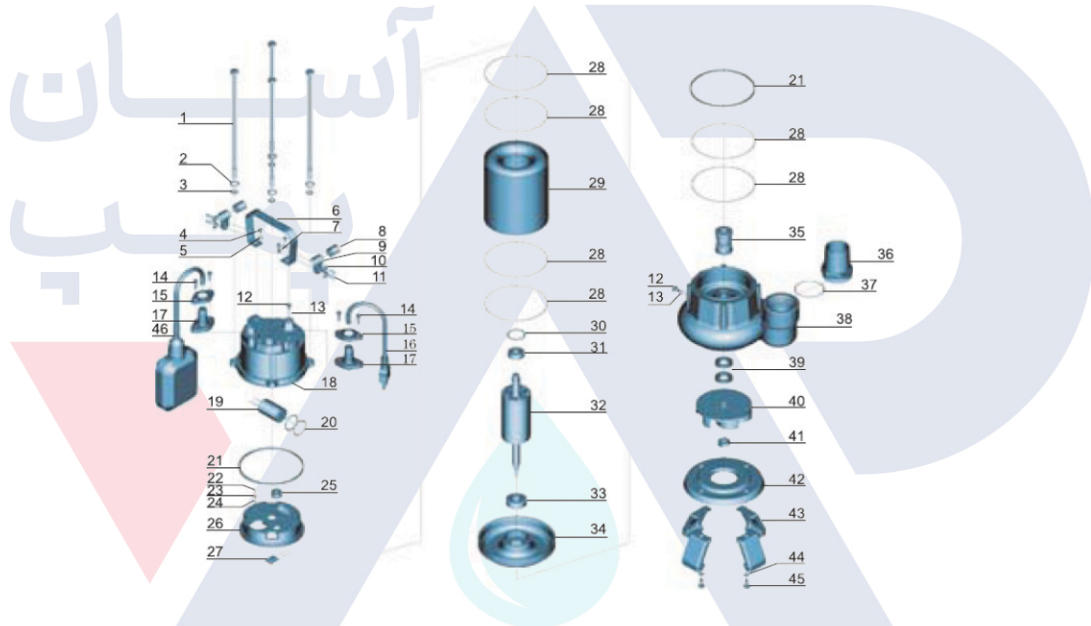

No.	Part	Material	No.	Part	Material
1	Bolt	Stainless steel	24	Washer	CuZn40
2	Stretching washer	Stainless steel	25	Cable holder	NBR
3	Washer	Stainless steel	26	Upper cover	HT200
4	Bolt	Stainless steel	27	Thermal protector	
5	Washer	Stainless steel	28	O-ring	NBR
6	Handle	Stainless steel	29	Stator	
7	Nut	Stainless steel	30	Wave washer	65Mn
8	Protector	NR	31	Ball bearing	
9	Cable presser	Stainless steel	32	Rotor	
10	Washer	Stainless steel	33	Ball bearing	
11	Screw	Stainless steel	34	Lower cover	HT200
12	Bolt	Stainless steel	35	Mechanical seal	Carbon/Ceramic
13	O-ring	NBR	36	Connector	ABS
14	Screw	Stainless steel	37	O-ring	NBR
15	Flange	Stainless steel	38	Pump body	HT200
16	Cable		39	Oil seal	
17	Cable protector	CR	40	Impeller	HT200
18	Capacitor cover	HT200	41	Nut	Stainless steel
19	Capacitor		42	Pump cover	Stainless steel
20	O-ring	NBR	43	Base plate	Stainless steel
21	Rubber washer	NBR	44	Washer	Stainless steel
22	Screw	CuZn40	45	Bolt	Stainless steel
23	Stretching washer	65Mn	46	Float switch	